



# PSI Parallel Seismic Instrument

Advanced, Friendly, Robust

## Product Data Sheet



## PSI—Parallel Seismic Instrument

PSI uses the well-known Parallel Seismic method to establish the depth of existing foundations (specifically piles) where the superstructure precludes access to the pile heads.

The test requires the installation of a plastic access tube in parallel, and as close as possible, to the tested pile. The tube should be carried down to a depth exceeding the assumed pile length by a margin of 8-10 m and filled with water. In unsaturated soils the tube should be firmly grouted in the hole to achieve good acoustic coupling with the surrounding soil.

### System Components:

- PSI instrument
- Sledgehammer with a trigger switch
- Digital depth meter (Optionally wireless)
- Hydrophone

### Operation:

As the hydrophone is lowered in stages inside the access tube, the superstructure is hit with the hammer and the pulse arriving at the hydrophone is recorded in the PC that is connected to the instrument. When all the pulses thus collected are plotted versus the respective depths, they show a typical break in the slope at the depth where the pile tip is located.

### Advantages:

- Ease of use: It is usually self-taught in less than a day. No additional expensive training is needed.
- Connects to any PC/Laptop via a standard USB port.
- Interpretation assistance and Second

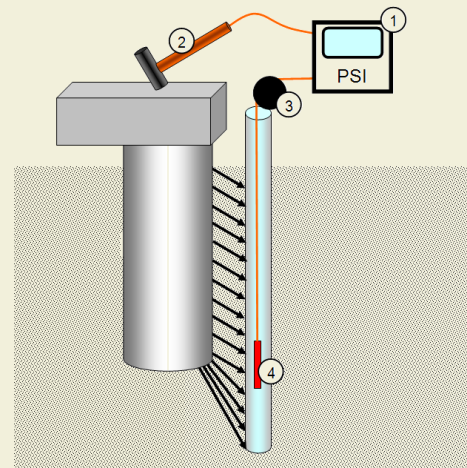

System Components

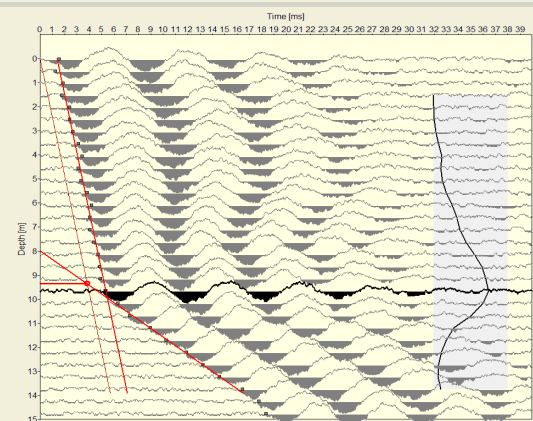

Output

## PSI - Technical Specifications

<b>Physical</b>	<b>Housing</b>	Rugged, Environment-proof, water-resistant housing
	<b>Dimensions</b> (mm)	430L x 325W x 105H (instrument only)
	<b>Weight</b>	2.6 kg (instrument only)
		4.2 kg (with typical computer)
	<b>Temperature range</b>	Operating : -25 to 60 (°C) Storage : -40 to 70 (°C)
<b>Power</b>	<b>Internal</b>	Rechargeable Lithium Ion battery More than a full day of typical use.
	<b>External</b>	100 ~ 240V AC operation/charging 12V DC car battery operation/charging
<b>Standards</b>	<b>AFNOR NF P94-160-3</b>	Fully meets or exceeds
<b>Technical</b>	<b>Hydrophone</b>	20Hz ~ 1kHz in stainless enclosure. 25 mm diameter
	<b>Cables</b>	Heavy-duty polyurethane on reel.
	<b>Sample rate</b>	50kHz (20µS resolution)
	<b>Gain</b>	8 levels automatic gain control (AGC)
	<b>Depth</b>	24-bit counter. <0.1% error.
<b>Performance</b>	<b>Pile lengths</b>	1 m to 145 m
	<b>Productivity</b>	10-15 min (typical) per pile
	<b>Storage</b>	Unlimited
<b>Requirements</b>	<b>Computer (Minimum)</b>	Windows XP/Vista/Win7. 800x600 resolution
<b>Output</b>	<b>Reporting</b>	Arrival time vs. depth
		Pile tip depth
Wave speed in pile		
	<b>Language</b>	Multi-lingual report generation in MS Word format
<b>Options</b>	<b>Cable reels</b>	50m, 100m, 150m and custom made lengths





## PILETEST

### Company profile

At Piletest we develop and manufacture systems for quality control / quality assurance of deep foundations since 1996. Our focus has always been on quality, modularity and ease of use.

### Quality

All products undergo extensive testing, including pressure chamber, vibration table, heat oven and more, and carry a full three (3) year warranty (Excluding physical damage).

### Modularity

We focus on building pile testing systems, not on computers. Therefore, all our products connect to a standard PC, Laptop, Tablet, Smartphone via USB or Bluetooth connection. This approach minimizes your downtime and keeps you up-to-date and independent, and reduces your overall costs.

### Ease of use

We take simplicity and usability very seriously. As a result no formal training is usually required and our users usually start using our systems out-of-the-box within minutes. Our ease of use knowhow, is based on years of field work before started designing our own equipment.

### Support

It is important for us, as well as it is for you that your final product—the *test report*, is of the highest standards. To help you with this we provide free on-the-job training. We also support you with the analysis of your first projects, and can revise the next ones and comment on the following ones, until we are both satisfied with the results.

**CHUM** .....

Cross Hole Ultrasonic Monitor



**PET**

Pile Echo Tester

Model PET Pro USB .....

Model PET Bluetooth .....

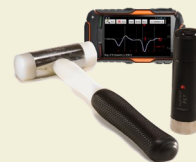

**BIT** .....

Borehole Inclination tester



Contact Information

Phone: +44 870 752 4081

Fax: +44 870 123 1738

Email: [sales@piletest.com](mailto:sales@piletest.com)

WEB: [www.piletest.com](http://www.piletest.com)

Address: 20-22 Wenlock Road,  
London N1 7GU  
United Kingdom

**CHUM**

**The CHUM (Cross Hole Ultrasonic Monitor)**

uses the Crosshole Sonic Logging (CSL) method (ATSM D6760-08) to perform high-resolution quality control on deep foundations.

The system uses an ultrasonic wave sent from an emitter to a receiver while both are pulled through water-filled access tubes embedded in the concrete. The measured arrival time and energy are directly related to concrete quality.

Additional methods supported by the CHUM are Single Hole Ultrasonic Testing (SHUT) and Tomography (two- and three-dimensional).

**Main features:**

- Easy to use; The user-friendly software makes it possible to master the CHUM in less than a day. No additional expensive training required
- Powerful tomography features
- Unlike other system based on an embedded computer (which may soon become obsolete), CHUM connects to the USB port of your regular notebook computer or Tablet PC.

**The basic CHUM package includes everything required to perform CSL and 2D tomography:**

- The CHUM instrument, two ultrasonic transducers, two 50m cable reels, two depth meter pulleys, cables and AC power adapter
- Optional: 100m/150m cable reels, 3D tomography
- Testing, analysis and reporting software
- Interpretation assistance package
- 10 years of free software upgrades
- 3 year warranty on hardware



The **CHUM** system  
(computer not included)

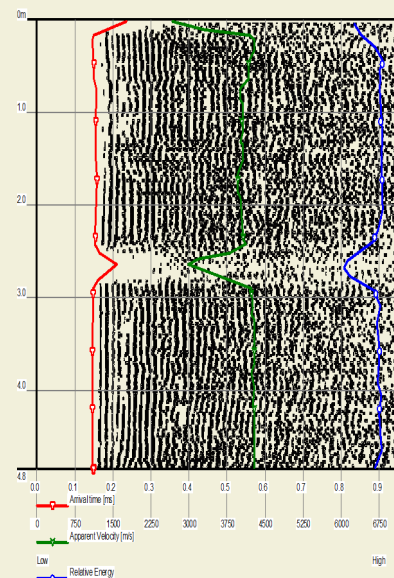

Typical output

3D tomography is available as a free on-line service for 1 year

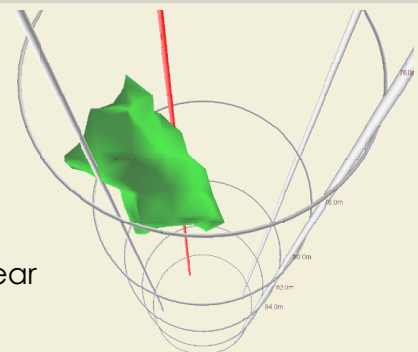

## CHUM 3DT

The CHUM 3DT (3D Tomography software for CHUM) is the most advanced, easiest to use and highly practical 3DT solution available today.

3D Tomography reveals and organizes information about flaws in the piles in a human-readable form and helps making well-informed decisions.

### Main features:

- Easy to use: Wizard-based interface hides the complexity of the calculations.
- Interactive UI—Zoom, rotate, tilt.
- lightning-fast calculations and graphics.
- Vertical and horizontal slices at any depth/direction.
- Immediate velocity threshold selection.
- Wireframe, Opaque and semi-transparent options help visualize the flaws.
- Create a report in a video clip form, in a document form or hand over the free 3DT viewer for anyone to view the results interactively.
- 10 years free software upgrades.

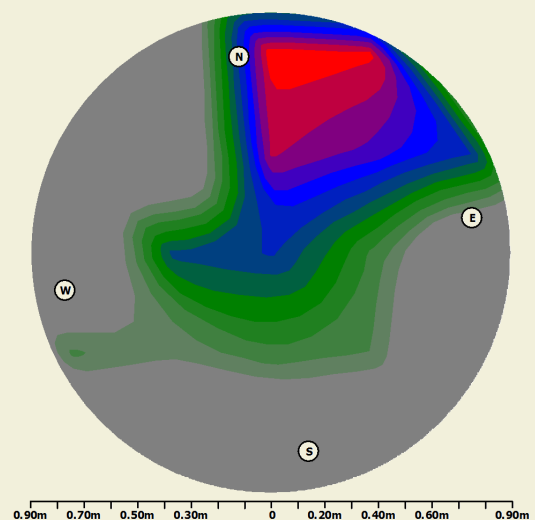
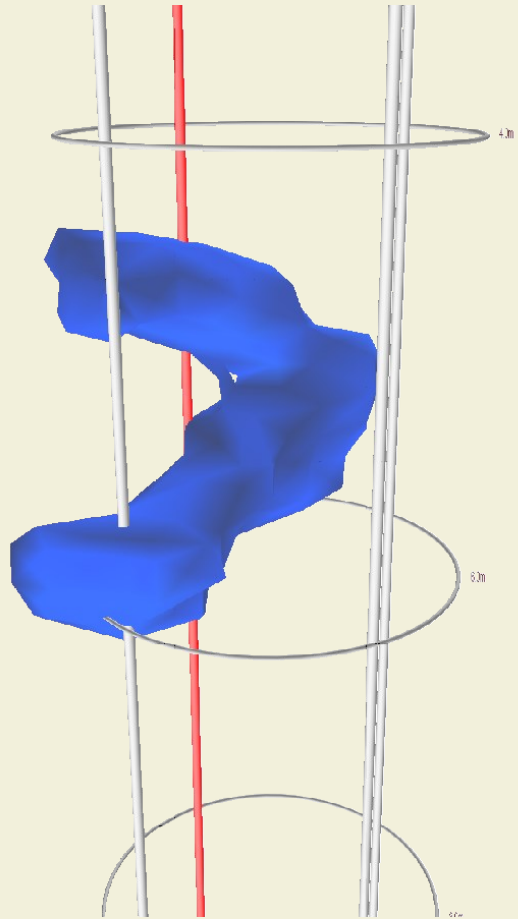



## PET—Pile Echo Tester (Model: PET Pro USB)

**Piletest's Pile Echo Tester (PET)** is a user-friendly, highly flexible solution for testing a large number of deep foundations quickly and accurately.

Requiring little-to-no training, PET is a modular, computer-independent system that attaches to the USB port of any regular notebook or a Tablet PC.

The PET system utilizes the pulse-echo method (compliant to the ASTM D5882-07 international standard). To test a pile, the user strikes it with PET's lightweight handheld hammer. The resulting signal, or reflectogram, is captured by PET's digital accelerometer. It is then transmitted to the computer to produce information about the pile's length and shape.

### Main Advantages

**Ease of use:** PET's user-friendly software makes it possible to master the system in less than a day. No additional expensive training is required

**Excellent signal quality:** PET's super low noise level enables the system to handle extremely long piles

**Computer independence:** Unlike other system based on an embedded computer (which may quickly become obsolete) PET connects to the USB port of your regular notebook computer or Tablet PC.

**Labor saving:** PET includes a number of labor-saving features such as advanced project organization; software-suggested wave velocity; Smart Trigger™ and AutoSort to reject anomalous blows; one-touch controls of scale, amplification, and filtering; plus many more features.

**Robustness:** Specially designed for testing piles, shafts and caissons in construction site environments. The PET sensor is IP67 waterproof and comes with a three (3) year warranty.

### The PET Pro USB package includes:

- A digital transducer with waterproof USB cable
- A nylon hammer, spare tips, special putty
- Testing, analysis and reporting software (unlimited number of licenses)
- Interpretation assistance package

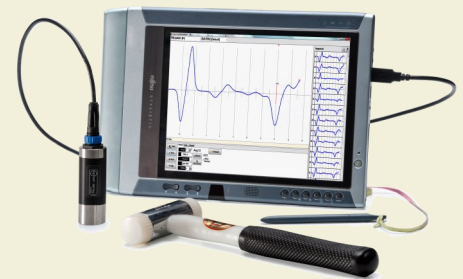

PET Pro USB with a Tablet PC (not included)

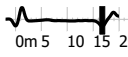
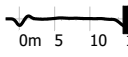
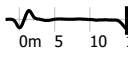
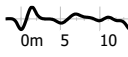
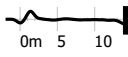
Pile	Depth (m)	Reflectogram	Details	Remarks
S*/9	16.8 m		Amp:75 Planned:16.0m Avg:5	
S*/13	15.0 m		Amp:55 Planned:15.0m Avg:9	
S*/14	15.4 m		Amp:55 Planned:15.0m Avg:12	
S*/15	14.0 m		Amp:50 Planned:13.0m Avg:17	Anomaly at 5.1m
T/13	14.2 m		Amp:120 Planned:14.0m Avg:11	

Typical output



On site



## PET—Pile Echo Tester (Model: PET Bluetooth)

**Piletest's Pile Echo Tester (PET)** is a user-friendly, highly flexible solution for testing a large number of deep foundations quickly and accurately.

Requiring little-to-no training, PET is a modular, computer-independent system that connects to any compatible computer via Bluetooth protocol.

The PET system utilizes the pulse-echo method (Compliant to the ASTM D5882-07 standard). To test a pile, the user strikes it with PET's lightweight handheld hammer. The resulting signal, or reflectogram, is captured and transferred to the computer by PET's digital accelerometer, providing real-time information about the length and shape of the pile.

### Main Advantages

**Ease of use:** PET's user-friendly software makes it possible to master the system in less than a day. No additional expensive training is required.

**Excellent signal quality:** PET's low noise level enables the system to handle extremely long piles.

**Computer independence:** PET Bluetooth connects to any existing or future computer. PET Bluetooth also connects to any Android phone or tablet. There is no dependency on an embedded computer (which may quickly become obsolete).

**Labor saving:** PET software includes a number of labor-saving features such as advanced project organization; software-suggested wave speed; Smart Trigger™ and AutoSort to reject anomalous blows; one-touch controls of scale, amplification, and filtering - plus many more features.

**Robustness:** Specially designed for testing piles, shafts and caissons in construction environments. The PET sensor is made of bullet-proof unbreakable Lexan. It is waterproof and carries a three (3) year warranty.

### The PET package includes:

- A digital transducer
- A nylon hammer, spare tips, special putty
- Testing, analysis and reporting software
- Interpretation assistance package
- Unlimited number of software licenses

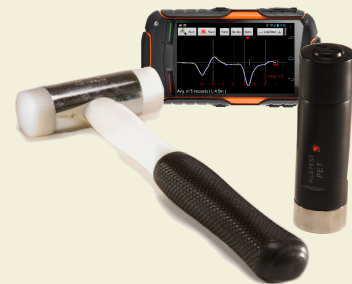

PET Bluetooth with an Android phone

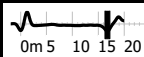
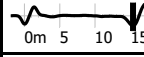
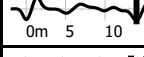
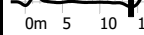

The PET package

Pile	Depth (m)	Reflectogram	Details	Remarks
S*/9	16.8 m		Amp:75 Planned:16.0m Avg:5	
S*/14	15.4 m		Amp:55 Planned:15.0m Avg:12	
S*/15	14.0 m		Amp:50 Planned:13.0m Avg:17	Anomaly at 5.1m
T/13	14.2 m		Amp:120 Planned:14.0m Avg:11	

Typical report

### BIT—Borehole Inclination Tester

All piling specifications prescribe the allowable deviation of the pile axis from the vertical. Typical limits vary between 1.33% (UK ICE) and 2% (US FHWA). In diaphragm and secant pile walls, the specification is typically even more restrictive.

Unlike traditional systems, BIT uses the auger/bucket itself as a centralizer, thus eliminating the need for a bulky system. The BIT enables fast and accurate determination of inclination in both dry and wet boreholes, vertical or raked.

Large boreholes and diaphragm-walls may be quickly tested several times during drilling to enable real-time corrective action.

Finished pile inclination can be measured through the CSL access tubes.

#### System components:

- BIT instrument, microcontroller-driven, with wireless communication to peripherals and durable cable connection to the sensor.
- Sensor including precision bi-axial inclinometer and a gyro, waterproof to 150m.
- Wireless depth encoder.
- Android smart-phone or tablet with software and Bluetooth communication (not included).
- Access-tube adapter (optional)

#### Operation:

In the open hole, the inclinometer is rigidly attached to the drill bit (bucket or auger) and the depth encoder hung from the rig. The bucket is then lowered (with minimal turning) into the open hole. The descent is stopped at predetermined depths for inclination reading and the deviation calculated in real time by integrating the inclination over depth. When pulling the bucket upwards to the surface, the procedure is repeated. The resulting closure error is distributed over the whole depth.

With the optional access-tube adapter, the BIT can also check the as-made inclination of bored piles.

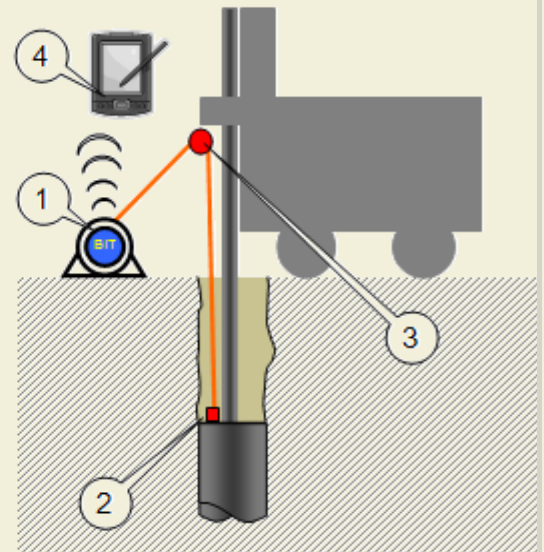

Schematic view



The BIT system

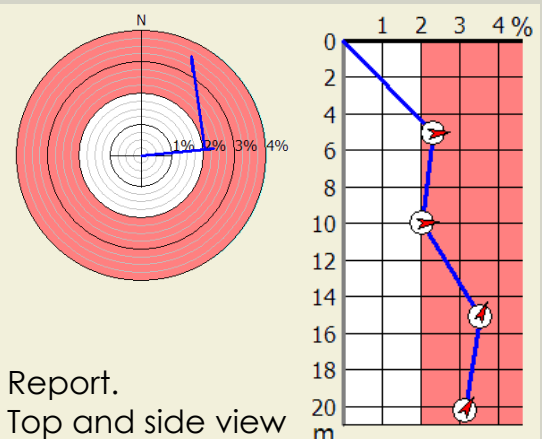

Report.  
Top and side view



**Contact Information**

**Phone: +44 870 752 4081**

**Fax: +44 870 123 1738**

**Email: [sales@piletest.com](mailto:sales@piletest.com)**

**WEB: [www.piletest.com](http://www.piletest.com)**

**Address: 20-22 Wenlock Road,  
London N1 7GU  
United Kingdom**



20-22 Wenlock Road | London N1 7GU | United Kingdom  
Phone: +44 870 752 4081 | Fax: +44 870 123 1738 | [sales@piletest.com](mailto:sales@piletest.com)  
[www.piletest.com](http://www.piletest.com)